

Notes on rigging of Optimists

Paddle or preferably a **Praddle**. The latter allows one handed paddling. Must be tied on, but still able to be used on both sides of the Opi.

Bailer Large capacity. Tied on with a 2-3m rope to enable it to be used whilst sailing.

Burgee Clipped to the top of the mast. Most people can't sail without one.

Mast tie down

A rope is recommended. If using a peg system then ensure it works. If the mast comes out of the mast step during a capsize then it could rip out the mast thwart (1) when the boat is righted.

Painter

One floating painter 9m long for towing. It should be securely tied to the mast thwart or mast step (2). This painter should have a loop in the rope approximately 60 cm (2 feet) forward of the mast.

Buoyancy tanks

Need buoyancy bags or equivalent inside and means of draining

Daggerboard

Shockcord for normal sailing. Retention line: to stop daggerboard falling out when capsized, but it must be quick release to enable a fast tow to be secured or removal by someone outside the boat.

Boom to mainsheet connection

Boom strop should be of kevlar or dynema rope and very tight. The maximum gap, ie at mainsheet position, should be less than 100mm. Add a separate loop around both the strop and boom at the mainsheet position: this stops a head filling the hole and helps control the gap.

Mainsheet

A lockable snap shackle is to be used to secure the mainsheet to the boom. These are useful for towing, lee shore landings and general on-shore use. **It must be a piston type snap shackle** - a spring loaded jaw type is not allowed because these have snapped on to buoyancy aids when the child has capsized. Very dangerous!

Toe straps

Use shockcord to keep the toe straps tensioned and clear of the bottom. This makes them easier to get feet underneath. It also means they give so you don't trip over them so easily.

Buoyancy bags

Need 3 straps to secure them properly. Straps should be secured to bottom of hull, not to the gunwale (3). This keeps the bags lower down and makes them more effective. Make sure the bags are fully inflated. Watch out for **mice eating** buoyancy bags if your Opi is stored upside down.

Rudder

Needs retaining clip to stop rudder falling off when capsized and lifting off when sailing or grounding. **Pintles (4)**: the lower one should be longer and locate in the gudgeon (4) (hole) 1cm or so before the top one. This makes it a lot easier to fit the rudder.

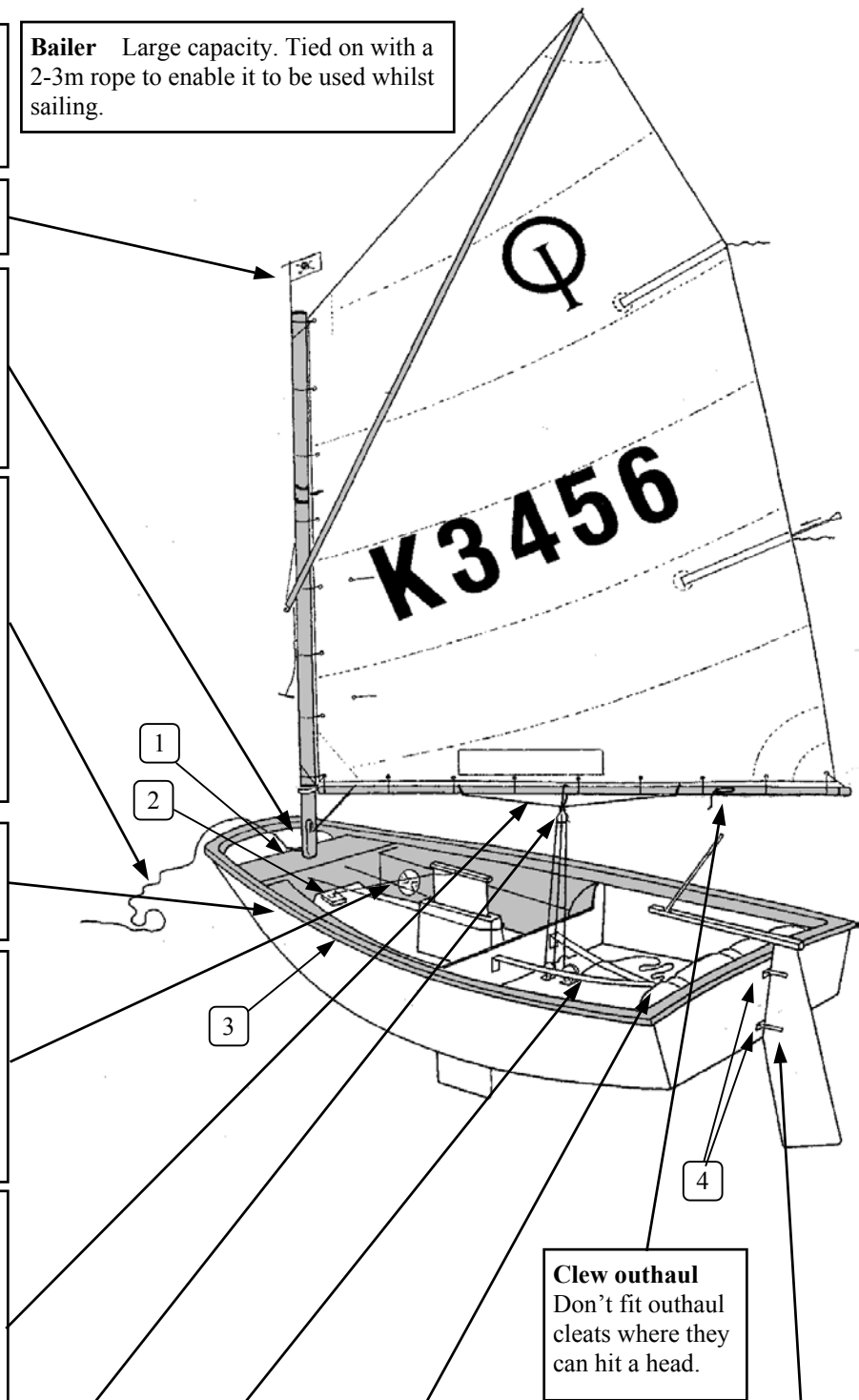

Notes on rigging of Optimists

Knots

All sail ties	Reef knots
End of all ropes	Figure of eight
Thin to thick rope	Sheetbend (single or double)
Shockcord to shockcord	Sheetbend (pulled very tight) or fishermans bend
Shockcord to rope	Double sheetbend with loop in shockcord
Painter to boat	Bowline, do not put a figure of eight in the free end, make sure the end is well sealed by burning.
Mast securing rope	reef knot, it must allow the mast to rotate and also tight enough to restrain the mast.
Knots in sprit rope	Consider whipped eyes to reduce bulk, otherwise use bowlines
All permanent knots	Use bowlines or sheetbends (single or double). Never use reef knots.

Ropes

These must be thick enough to jam correctly in the cleats. For clam cleats; 8 plait or 3 strand works well. For V cleats; only use 3 strand.

Main sheet	Usually 8mm 8 plait with a soft covering.
Boom strop	4/5 mm kevlar or dynema, this must be tight with no stretch. Wire is not recommended as it won't give if it hits your child when gybing, or starts fraying.
Sprit control	5/6 mm kevlar or dynema, wire can be used for part attached to the sprit

Setting up the sail for average conditions.

Attach all sail ties. Adjust top diagonal tie so that the top mast tie runs normal to the mast (not at an angle).

Put the mast in and attach the boom and kicking strap.

Put the sprit in but don't tighten yet

Put the boom height control rope on and adjust until the luff is just tight.

Adjust the kicking strap by just removing the slack, do not over tighten.

Adjust sprit: tighten until a diagonal crease appears in the sail. Pull in the sail and the crease should just about disappear.

Other points

If you are worried about a sore head from boom contact, then you can fit pipe lagging to the boom.

See the IOCA log book for more details of terminology.

General

If in doubt please ask, but please note that the instructors may be busy with organising rescue boats, children, activities (or their own children). So you will have to try and catch them at a slack time or ask someone else.

Please note that Optimist sail adjustment is an art form, most other dinghies are a doddle in comparison, so you won't be the only one having problems.

It is a good idea to look carefully at several other good boats (usually ones in the racing fleet) and ask experienced parents before making any changes.

Join IOCA, to get the IOCA log book and a magazine. The club uses the IOCA scheme, not the RYA scheme which is slightly different

Books Beginners - Sailing for Kids by Gary and Steve Kibble, Fernhurst Press (was The Prudential book of Sailing, A Guide for Young People.)

 More advanced - Optimist Racing by Phil Slater, Fernhurst Press

Notes on rigging of Optimists

Rigging

These notes are for beginners and intermediates, racing setup is different.

The five corner ties take a lot of load and must be of good quality rope. Failure of these ties may result in a torn sail.

For all these main ties use 2 turns of 2mm dynema. Using 2 turns gives better control of the tightness at each of these ties. The other mast ties should be just tight, with a slight gap between sail and mast. The boom ties should allow a slight gap between sail and boom.

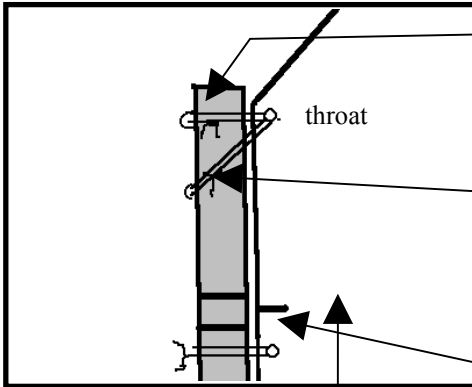

The **top tie** needs to be tight.

The **top diagonal tie** must be adjusted such that the top tie will not jump off the top of the mast and so that the **black sail mark** is between the 2 **mast black bands**.

Black bands, see **top diagonal tie**.

There should be a **clew tie** which must be tight. The clew tie is in addition to the **clew outhaul**. The clew tie helps to give extra head clearance under the boom, as well as leech control

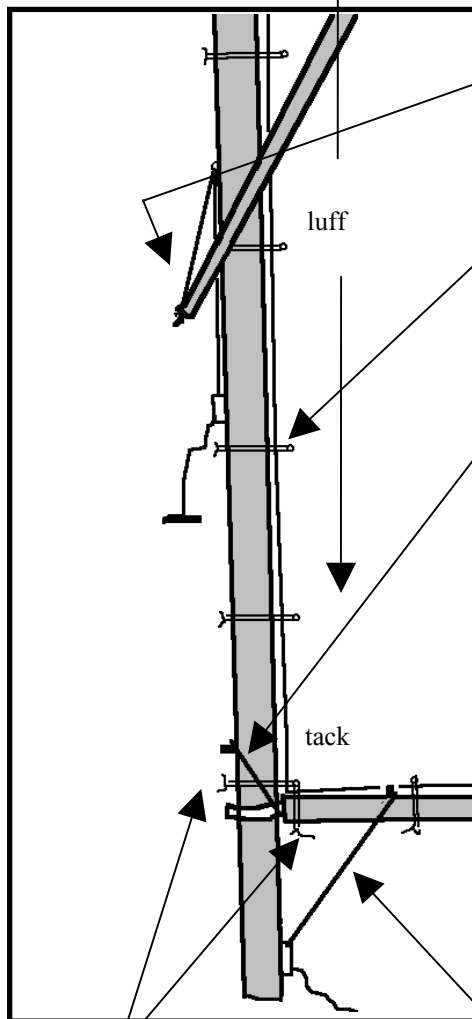
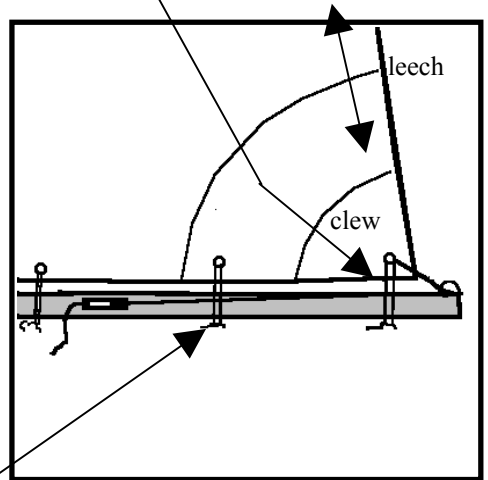

Sprit control rope. Tight enough to put a diagonal crease in the sail which disappears when the sail is pulled in fully.

Sail ties. Just tight on the mast, slightly loose on the boom.

Boom height adjusting rope. This is used to stop the outboard end of the boom lifting in strong winds when sailing downwind and also controls tension in the luff.

Boom stop. This is used to stop the boom bending too much in strong winds to control tension in the leech.
Note: The maximum gap must be less than 100mm (4"). Fit a second loop at the block position to control this.

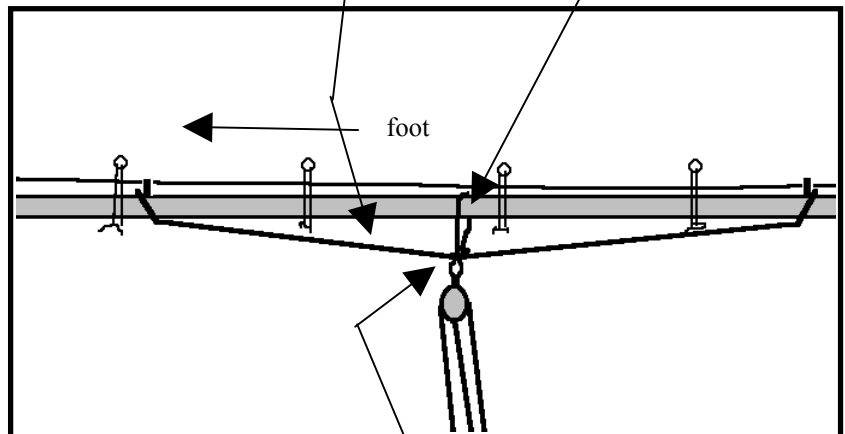

The two **tack ties**, ie bottom corner of the sail to the mast and bottom corner of the sail to the boom must be tight.

Kicking strap or boom vang. Don't overtighten

Piston Snap shackle to allow quick release of sail from mainsheet.